

# MODE

## BATHROOMS

SE30696C0

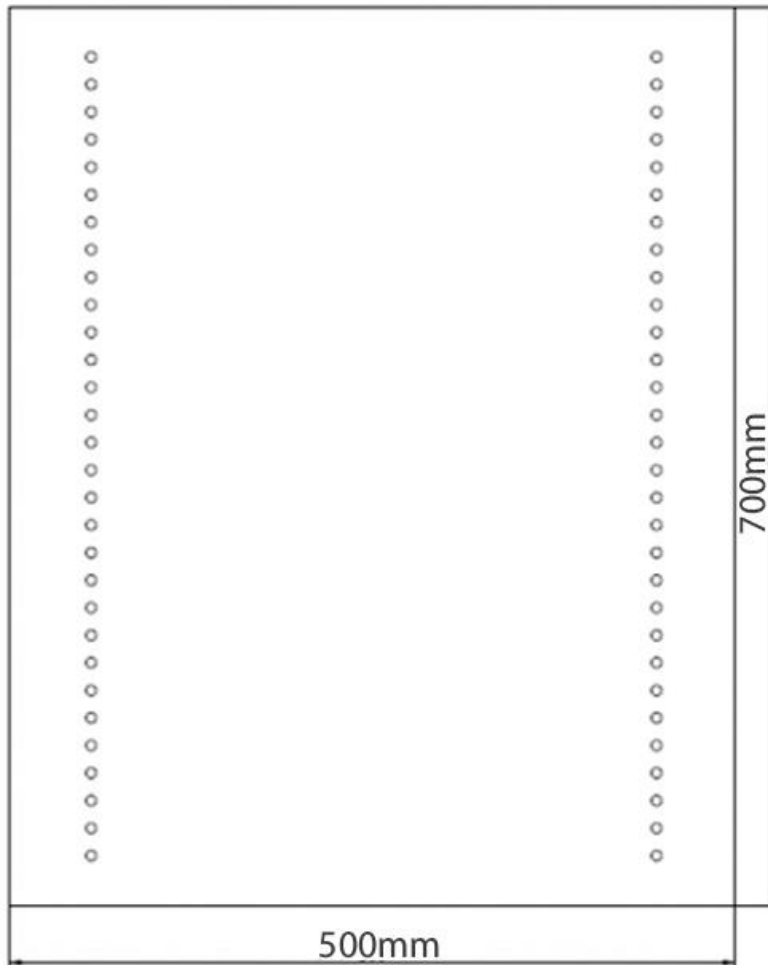
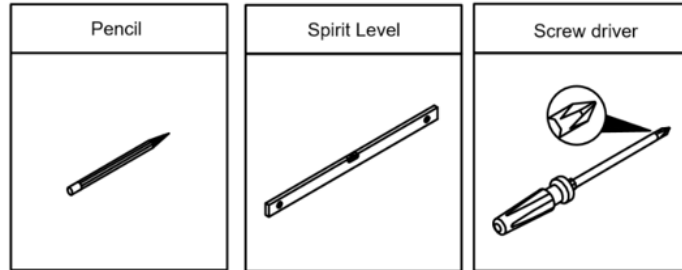

Exclusively available @

**VictoriaPlum.com**

VictoriaPlum.com  
0344 804 48 48

## **BATHROOM FURNITURE FITTING GUIDE**

**Please spend 5 minutes reading this section before commencing with the installation of your new furniture.**

1. Should any of your items have a defect, please do NOT install as returns will not be accepted once fitted.
2. We advise that you use a qualified person to install your units, as any issues relating to poor fitting will not be accepted by the supplier.
3. You have purchased a handmade and in some cases hand painted product, therefore you may see some slight imperfections which the supplier may deem as acceptable.
4. This product is water resistant but NOT waterproof. On no account should any spillages or splashes, even water, be allowed to lie on any surface. All spillages and splashes should be wiped dry, failure to do so may shorten the life expectancy of the product and invalidate any guarantees.
5. Please avoid direct sunlight as this will cause the painted surfaces to discolour.
6. Due to motion in transit, the cabinet doors and drawers may need to be adjusted after installation.
7. Floor standing units must be fitted back to the wall through the back rail using suitable fixings (not supplied).
8. Basin units should be fitted as above. The basin should also be secured where applicable using Fischer bolts through the fixing points under the basin (not supplied). Note that not all basins have this facility.
9. Wall hung units must be secured back to the wall using the wall hanging brackets or suitable wall fixings when not supplied. Additional support is recommended using 'L' brackets (not supplied).
10. The hinge on the laundry basket can be adjusted by slackening the screw on the side of the sliding bar.
11. When fixing to a stud or panelled wall, appropriate frame work should be installed to support the basins and units.
12. Where units or worktops have to be cut-out for services, all raw edges MUST be sealed against water ingress.

### **Hinge adjustment**

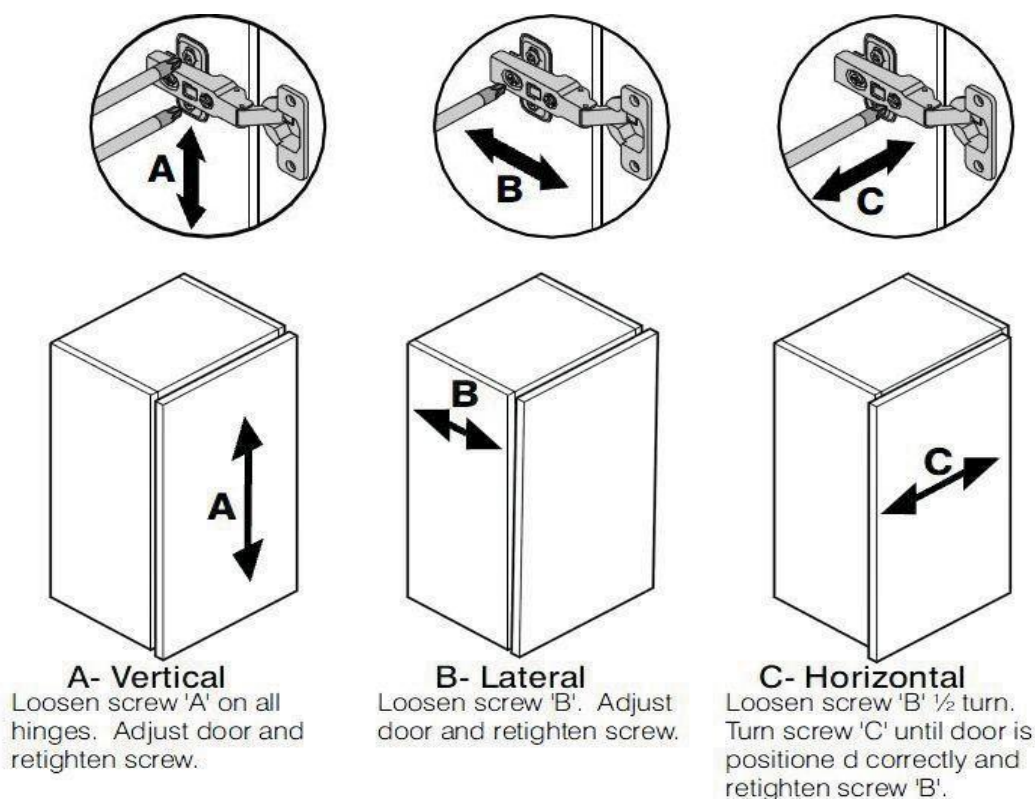

## **BATHROOM FURNITURE CUSTOMER CARE GUIDE**

**Please note that although these units have been designed to give years of pleasure and satisfaction, you will help maintain the original beauty of your bathroom by following these guide lines.**

### **Melamine, Vinyl and Foil Wrapped Doors**

Occasional marks, can in most cases, be removed with a soft damp cloth. More persistent marks can be removed using a non-silicone based furniture cleaner. Hot soapy water should be avoided. Once the mark is removed, the area should be wiped over with a damp cloth to remove any excess and dried with a soft clean cloth. On no account should solvent or an abrasive cleaner be used as permanent damage to the finish could take place.

### **High Gloss Doors**

Use a cleaning product not containing aggressive substances like acetone, alcohol, bleach ... as those components could seriously damage the surface of the door. The best would be to use a soft cotton or micro fibre cloth with only water and soft soap (containing a maximum 1% of liquid soap)

### **Carcase Components**

Do not use polish on any surfaces. A damp cloth with soapy water will clean off most marks or spills. Bleaches, scouring pads and multi-surface cleaners should not be used.

Drawers,

### **Runners, Door Hinges**

These should be wiped out with a damp soapy cloth and wiped dry with a soft cloth as necessary. The roller runners and hinges are lubricated and should not be cleaned with a degreasing agent as this will affect the action of the moving parts. Never lean on partially or fully opened doors and drawers in order to gain access to the units. The hinges are specified to adequately support the weight of the door, plus small additional weights such as wire accessories. It is advised that once the bathroom has been installed you should check every six months that all screws on the hinges are tight.

### **Worktops**

Although the worktop is hard wearing, sharp objects will scratch and excessive heat will scorch the surface. Care should be taken not to drop any heavy objects onto the worktop as the surface may crack. For cleaning, a damp soapy cloth will clean off most spills. Bleaches, scouring pads and multi-surface cleaners should not be used. Corrosive liquids and make-up should be wiped off immediately. On no account should any spillage, even water, be allowed to lie on the surface.

### **Temperature and Humidity**

Avoid excessive change in temperature and humidity. Always try to ensure adequate ventilation.

### **General care, spillages and splashes**

On no account should any spillages or splashes, even water, be allowed to lie on any surface. All spillages and splashes should be wiped dry, failure to do so may shorten the life expectancy of the product and invalidate any guarantees.

### **Regulations**

If it is your intention to remove and replace your bathroom fittings with "like for like" units, then this is classed as "non-regulated" and no building regulations would be required. However, building regulation approval may be required if the bathroom refurbishment involves altering the drainage or the internal layout within the dwelling to accommodate the new fitting such as a second bathroom. In this instance, we would advise you to contact the Building Control Department at your local authority to discuss the need for a formal building regulation application.

Macerator - Current building regulations specify that a Sani pump small-bore system can be fitted in a dwelling where there is also a normal gravity discharge W.C. It should not be the only W.C. facility. Electrical - Remember that double pole isolating switches are required for all electrical points apart from special razor sockets. All work must conform to BS7671: 2008 the current I.E.E. Regulations.

Exclusively available @

**VictoriaPlum.com**

**VictoriaPlum.com**  
**0344 804 48 48**

## **INSTALLATION INSTRUCTIONS**

**Please read these instructions before commencing installation and retain for future reference.**

### **Important safety information**

Please read these instructions carefully before attempting to install this product. It is advisable to keep these instructions in a safe place for future reference.

We recommend that you consult a qualified electrician. All electrical installation must be carried out in accordance with current IEE wiring regulations (BS7671).

These products must not be modified, if any modifications are made, it may invalidate the warranty and may render the product unsafe.

- This product should be used indoors.
- If in doubt installation must be carried out by a qualified electrician.
- Install on smooth flat surfaces only.
- Do not exceed or stretch the cable length of each LED wire.
- There are 60 x 0.07W high power LED's in this mirror.
- (W) 500mm x (H) 700mm x (D) 40mm
- Please make sure the LED's are working correctly before commencing installation.
- This mirror is rotation ready, so can be hung landscape or portrait.

### **Safety instructions**

1. Before commencing installation or maintenance, isolate the main electrical supply for the appropriate circuit at the fuse board.
2. This product is only suitable for connecting to a 240V 50Hz supply.
3. The mirror should be mounted onto a secure surface.
4. When installing please take care to avoid water pipes, joints and electrical cables.

### **Waste Electrical & Electronic Equipment (WEEE)**

The symbol on the product, or on the document accompanying the product – the crossed-out wheellie bin symbol – indicates that this product may not be treated as household waste.

Instead it shall be handed over to the applicable collection point for the recycling of electrical and electronic waste.



### **Maintenance & Care**

- Ensure that the power is disconnected prior to cleaning.
- To keep the finish of this product, wipe over with soft cloth periodically.
- Do not use harsh chemical solvents, this may dis-colour or damage the finish.

Exclusively available @

**VictoriaPlum.com**

**VictoriaPlum.com**  
0344 804 48 48

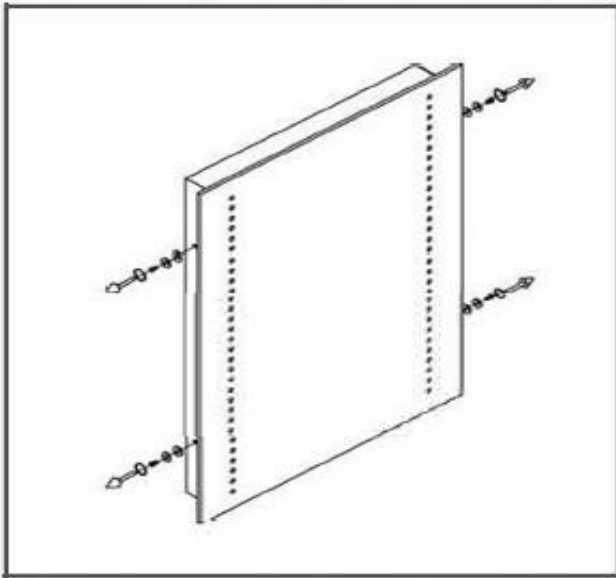

Lay the mirror on a flat surface with the front glass facing upwards. Using a Philips screwdriver, remove the four screws, along with the metal and white spacers on the sides of the mirror as shown above.

Carefully lift the mirror off the back box and position it onto a soft flat surface to avoid scratching the mirror.

Pierce the small protective IP rated rubber grommet (this will isolate and trap any steam to ensure maximum safety during use).

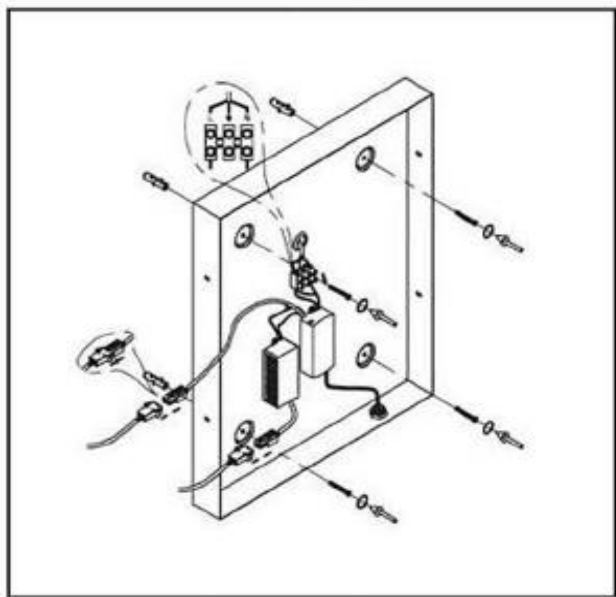

Insert a 3-core cable through the pierced hole in the protective cover, then thread the cable through from behind the back box into the power supply.

Mark the position of the fixing holes in the metal back box onto the wall, carefully avoiding any wiring or water pipes.

Next, drill and prepare the holes for the screws, ensuring that the wall is a solid material.

Mount the metal back box of the mirror onto the wall and secure tightly.

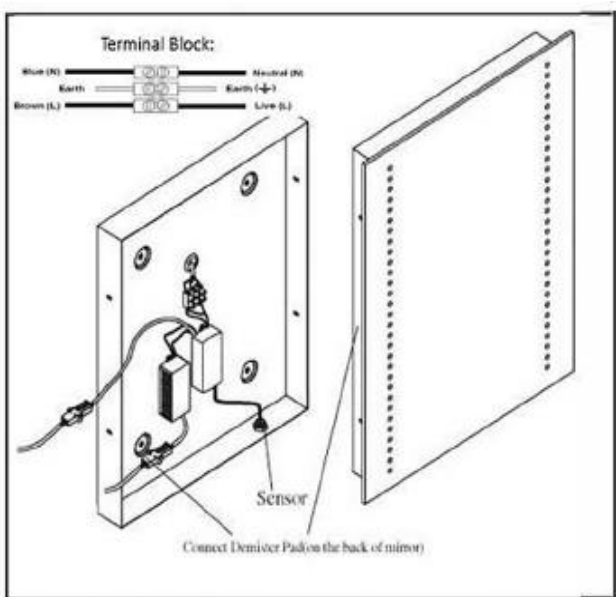

Using a flat-bed screwdriver, securely connect to the mains supply using the terminal block incoming neutral (blue/black) to neutral blue and incoming live (brown/red) to live brown. To connect the LED's, attach the male and female connectors. For the demister pad, connect the remaining male and female connectors together.

Attach the front glass panel safely onto the metal back box mounted on the wall. Secure tightly using the 4 screws and spacers.

Switch on the mains electrical supply. To activate the mirror, swipe your hand under the sensor switch.

0

Inside the bath or shower.  
Must be SELV (12V max.)  
due to water submersion.  
Minimum rating of IP67.

1

225cm above the bath or shower.  
Minimum rating of IP44.

2

The area stretching to 60cm  
outside the bath or shower and  
60cm from water outlet of sink. An  
IP rating of at least IP44 is required.

This mirror is IP44 rated and  
is suitable for installation in  
zone 2 and the outside  
zones.

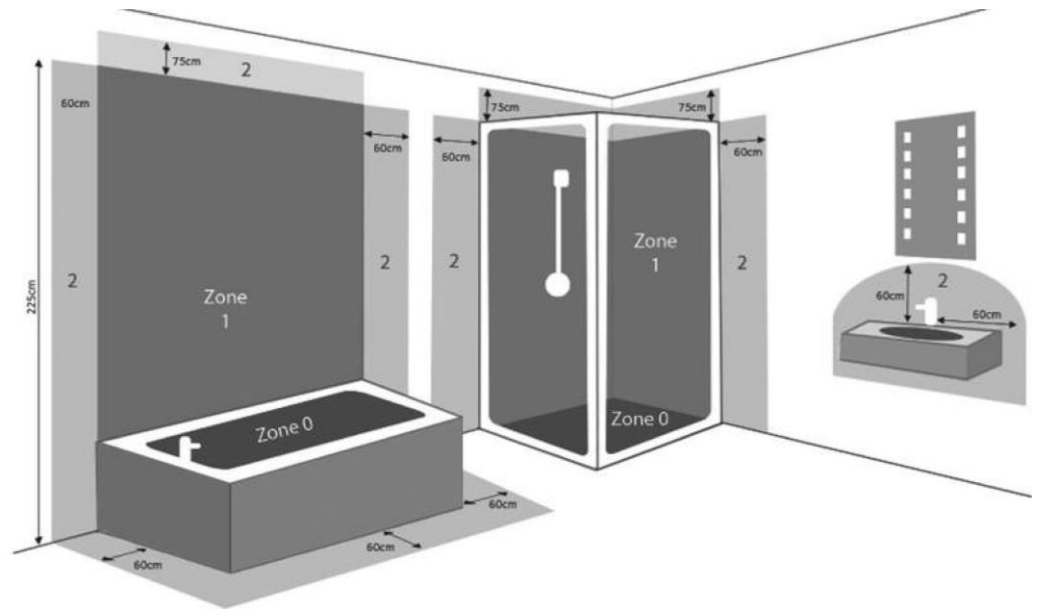

**OUTSIDE ZONES:** Anywhere outside zones 0, 1 and 2. Where water jets are not used for cleaning purposes, the general rules of BS7671 apply.

Exclusively available @

**VictoriaPlum.com**

VictoriaPlum.com

0344 804 48 48